

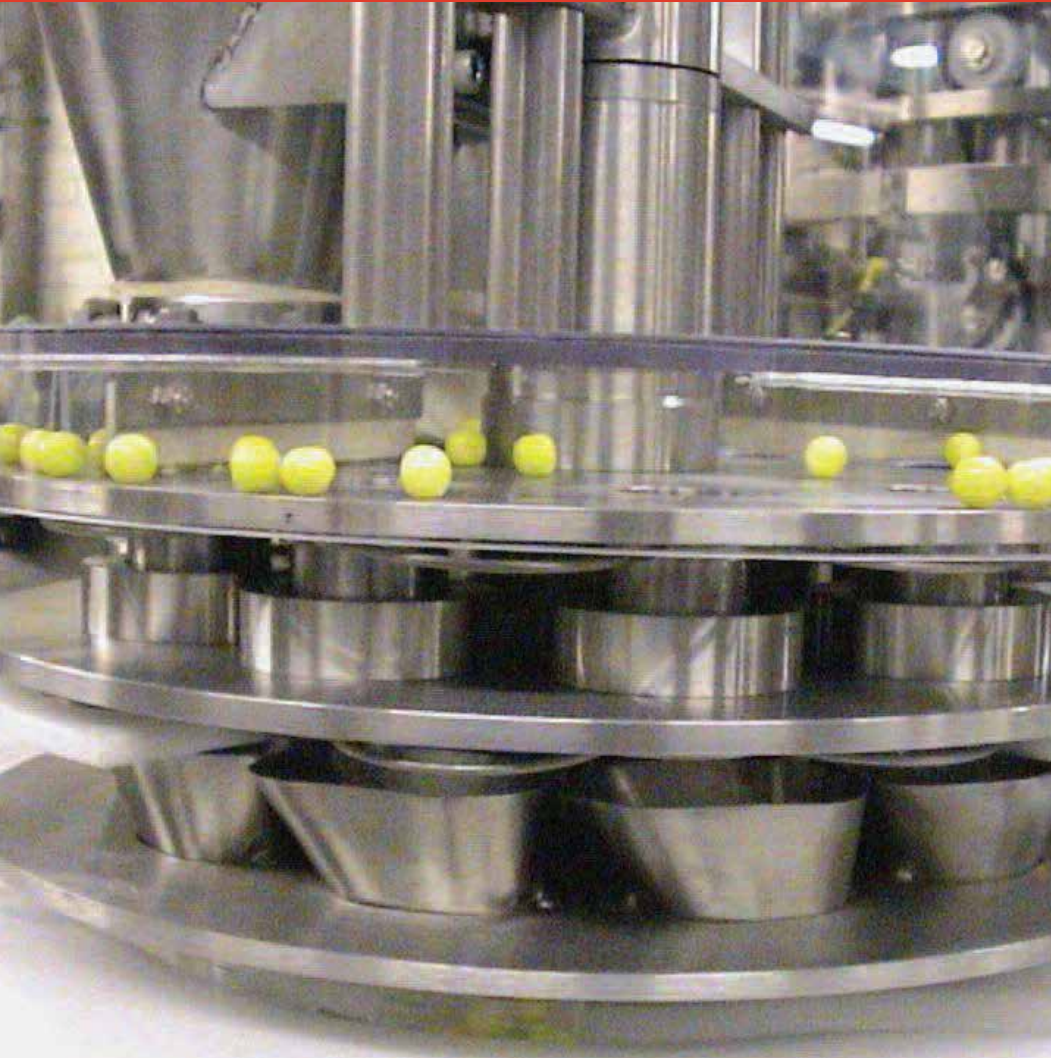

## ROTARY SOLIDS FILLER



### VERSATILE

- Designed for free flowing products
- Handles all types of rigid containers
- Fill range from 20gm up to 5kg
- Speeds from 30cpm up to 1000cpm
- Rapid changeover time
- No tools required for changeover

### FEATURES

- Very accurate fill
- 316 Stainless Steel contact parts
- No Container - No Fill System
- Precise adjustment of fill weights during operation
- Quick release telescopic measuring pockets
- Can be integrated with other equipment
- Colour coded change parts
- Guarding complies with CE regulations

### OPTIONS

- Product level control
- Product feed systems
- Modulated speed control
- Servo-adjustment of fill volume
- Performance monitoring

### Complete Systems for Solids Packing

- For:
- Rice
  - Pulses
  - Pasta
  - Vegetables (whole or sliced & diced)
  - Meat
  - Fresh Fruit
  - Dried Fruit
- and much more

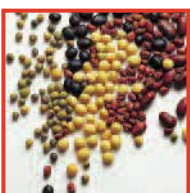

## ROTARY SOLIDS FILLER

Series	Head Range	Speed Range	Length	Height	Width	Power	Nett Weight Range
200	12-16	30-400	1200	1300	1300	1.6	1100
300	18-24	45-600	1500	1450	1700	2.1	1300
350	21-30	50-750	1660	1550	1900	2.4	1450
400	24-32	60-800	1900	1600	2200	2.7	1800
450	27-40	65-1000	2100	1700	2400	3.1	2300

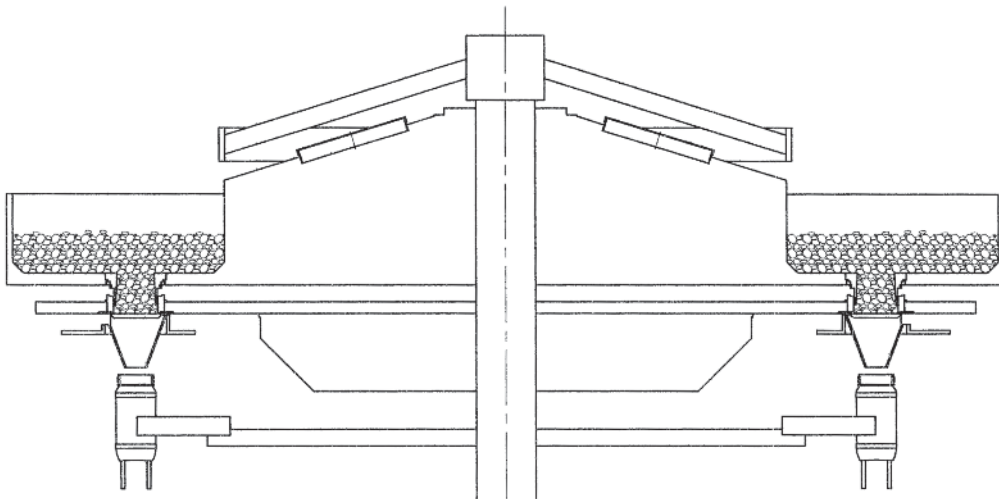

Maximum speed depends on the type of container, container shape, headspace, fill temperature and the nature of the product. • Electrics 380v 3ph 50hz • Air 30lt/min at 6 bar

### Total System Capability

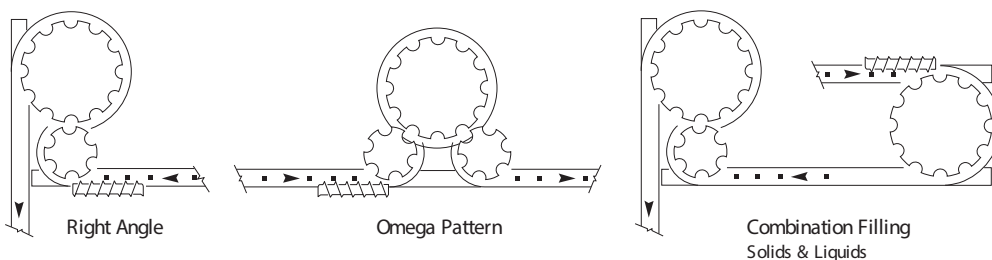

M&P (Engineering) Ltd.  
Trafford Park Road  
Trafford Park  
Manchester  
United Kingdom  
M17 1HG

Tel: +44 (0) 161 872 8378

Fax: +44 (0) 161 872 9250

Email: [info@mp-engineering.co.uk](mailto:info@mp-engineering.co.uk)

Web: [www.mp-engineering.co.uk](http://www.mp-engineering.co.uk)