



ROTARY PISTON FILLER



VERSATILE

- Extensive combination of models
- Handles all types of rigid containers
- Fill range from 50ml up to 5 litres
- Speeds from 30cpm up to 1,000
- User friendly
- Rapid changeover times
- No tools required for changeover

FEATURES

- Very accurate fill
- 316 Stainless Steel contact parts
- No Container - No Fill System
- Can be integrated with other equipment
- Cylinder capacity to suit application
- Patented non-drip filling nozzles
- Colour coded change parts
- Guarding complies with CE regulations

OPTIONS

- Product level control
- Scraper to maintain product mix
- Modulated speed control
- Servo-adjustment of filled volume
- Performance monitoring
- Temperature compensation
- Powered head height adjustment
- Powered adjustment of fill volume
- PLC controlled operation
- Quick release change parts
- Others available upon request

Designed to handle free flowing liquid or slurries

- For:
- Jams
 - Soups
 - Baby Food
 - Sauces
 - Purees
 - Cream
 - Milk Products
 - Fruit Juices
 - Chemical Products
 - Anti-freeze
- and much more



ROTARY PISTON FILLER

Series	Head Range	Speed Range	Length	Height	Width	Power	Nett Weight Range
200	6-16	30-320	1200	2300	1300	2.1	2000-2200
300	10-24	90-480	1500	2400	1700	2.5	2800-2920
350	21-28	100-560	1660	2500	1900	3.1	3200-3340
400	24-32	100-640	1900	2500	2200	3.8	3500-3660
450	27-36	100-720	2100	2500	2400	4.7	3880-4060
500	30-40	100-800	2300	2600	2600	5.8	4100-4300
Large Volume (up to 5,000ml)	10-16	12-80	2000	2900	2300	tbc	6000-6800

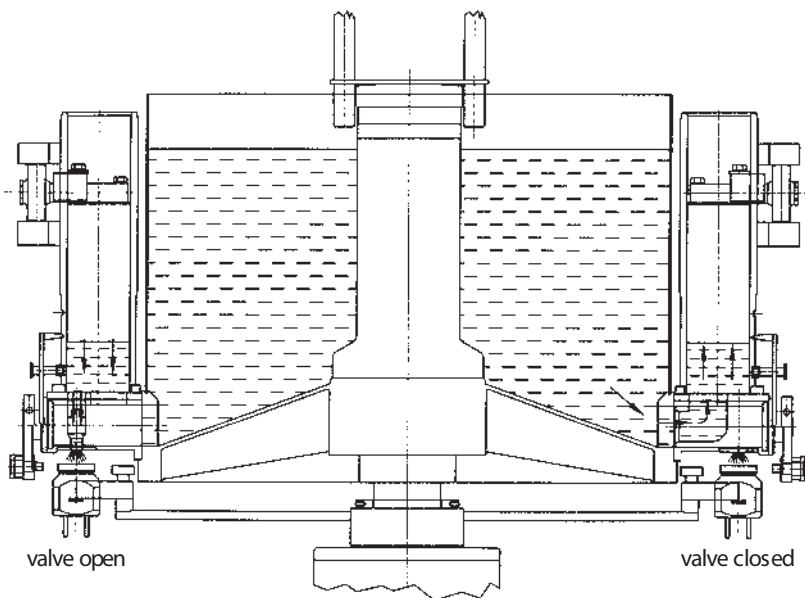

Maximum speed depends on the type of container, container shape, headspace, fill temperature and nature of the product. • Electric's 380V 3ph 50hz • Air 30lt / min at 6 bar

Total System Capability

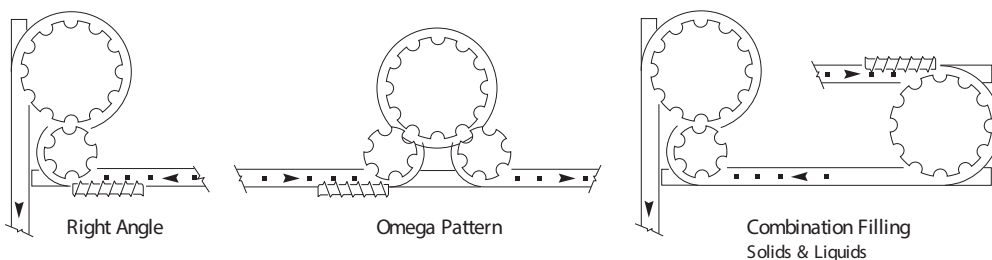

M&P (Engineering) Ltd.
Trafford Park Road
Trafford Park
Manchester
United Kingdom
M17 1HG

Tel: +44 (0) 161 872 8378

Fax: +44 (0) 161 872 9250

Email: info@mp-engineering.co.uk

Web: www.mp-engineering.co.uk